

XP / XR Series

by RadonAway



Features

- Low energy consumption
- Quiet operation
- Thermally protected motor
- ETL Listed - for indoor or outdoor use
- Meets all electrical code requirements
- Rated for commercial and residential use



Made in USA with US and imported parts.



Fan Specifications

Model	Fan Duct Diameter	Watts	Max. Pressure "WC	Typical CFM vs. Static Pressure WC			
				0"	.5"	1.0"	1.5"
XP151	4"	45-60	1.6	180	140	80	10
XP201	4"	45-66	1.9	125	105	70	35
XR261	6"	65-105	1.8	230	165	75	30

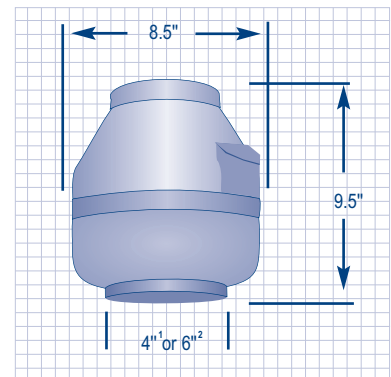

1 - XP151, XP201
2 - XR261