

RP Series

by RadonAway

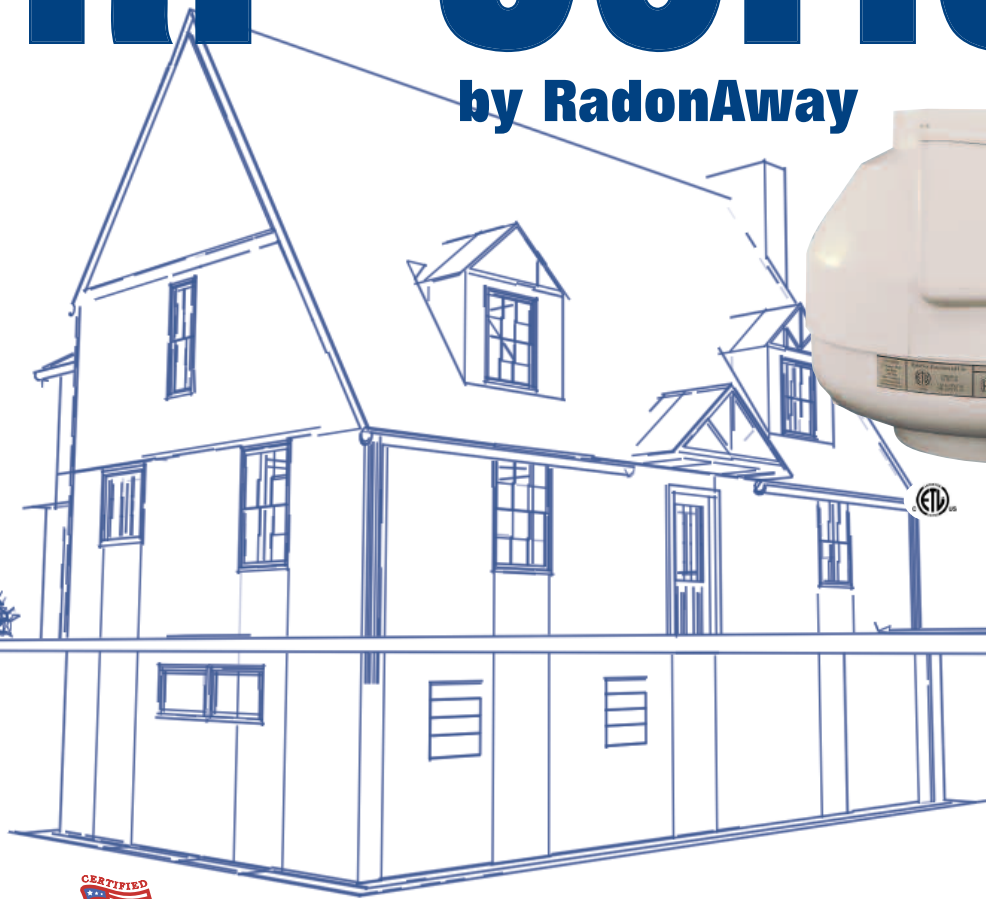

Made in USA with US and imported parts.

Features

- Energy efficient
- Super-quiet operation
- Thermally protected motor
- Motorized impeller
- ETL Listed - for indoor or outdoor use
- Meets all electrical code requirements
- Rated for commercial and residential use

Fan Specifications

Model	Fan Duct Diameter	Watts	Max. Pressure "WC	Typical CFM vs. Static Pressure WC				
				0"	.5"	1.0"	1.5"	2.0"
RP140	4"	14-20	0.8	134	68	-	-	-
RP145	4"	37-71	2.1	173	132	94	55	11
RP260	6"	52-72	1.8	275	180	105	20	-
RP265	6"	86-140	2.5	327	260	207	139	57
RP380	8"	103-156	2.2	510	393	268	165	38

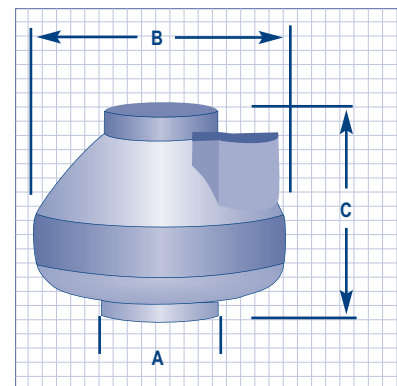

	A	B	C
RP140	4"	9.7"	8.5"
RP145	4"	9.7"	8.5"
RP260	6"	11.75"	8.6"
RP265	6"	11.75"	8.6"
RP380	8"	13.41"	10.53"